

Single 2-Input NAND Gate

General Description

The ET74AHCT1G00 is a single 2-input NAND Gate operating from a 4.5V to 5.5V supply. This device is fabricated with advanced CMOS technology to achieve ultra-high speed with high output drive.

Features

- Designed for 4.5V to 5.5V V_{CC} Operation
- Over-Voltage Tolerant Inputs Accept Voltages to 5.5V
- ±8mA Balanced Output Sink and Source Capability
- Near Zero Static Supply Current Substantially Reduces System Power Requirements
- These Devices are Pb-Free and RoHS Compliant
- ESD Protection Complies with JEDEC Standard
 - HBM: ±4000V Pass (JEDEC JS-001)
 - CDM: ±1000V Pass (JEDEC JS-002)
- Latch-up Performance Exceeds ±100mA per JEDEC JESD78F
- Part No. and Package Information

Part No.	Package	Packing Option	MSL
ET74AHCT1G00	SC70-5 (1.3mm × 2.1mm)	Tape and Reel, 3K/Reel	1
ET74AHCT1G00T	SOT23-5 (1.6mm × 2.9mm)	Tape and Reel, 3K/Reel	3
ET74AHCT1G00Y	DFN6 (1.0mm × 1.5mm)	Tape and Reel, 3K/Reel	1

Pin Configuration

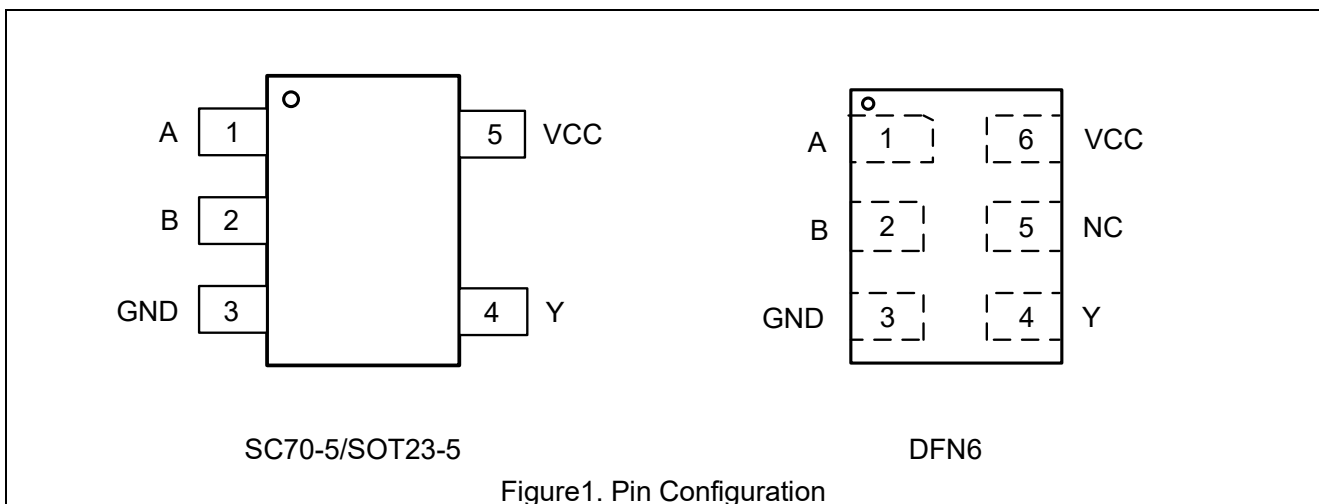

Figure1. Pin Configuration

ET74AHCT1G00

Pin Function

SC70-5 / SOT23-5

Pin No.	Pin Name	Function
1	A	Input A
2	B	Input B
3	GND	Ground
4	Y	Output Y
5	VCC	Supply Voltage

DFN6

Pin No.	Pin Name	Function
1	A	Input A
2	B	Input B
3	GND	Ground
4	Y	Output Y
5	NC	No Connect
6	VCC	Supply Voltage

Block Diagram

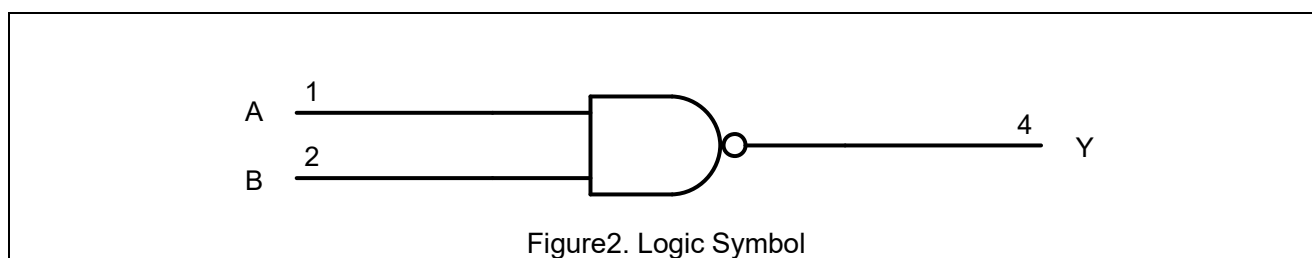

Function Table

Input		Output
A	B	Y
L	L	H
L	H	H
H	L	H
H	H	L

ET74AHCT1G00

Absolute Maximum Ratings

Symbol	Parameter		Value	Unit
V _{CC}	DC Supply Voltage (VCC Pin)		-0.5 to 7.0	V
V _I	DC Input Voltage ⁽¹⁾		-0.5 ≤ V _I ≤ 7.0	V
V _O	DC Output Voltage Output in Higher or Low State		-0.5 to V _{CC} + 0.5	V
I _{IK}	DC Input Diode Current, V _I < GND		-20	mA
I _{OK}	DC Output Diode Current, V _O < GND, V _O > V _{CC}		±20	mA
I _O	DC Output Sink Current		±12.5	mA
I _{CC}	DC Supply Current Per Supply Pin		25	mA
I _{GND}	DC Ground Current Per Supply Pin		-25	mA
T _{STG}	Storage Temperature Range		-65 to 150	°C
T _L	Lead Temperature, Soldering 10 Seconds		260	°C
T _J	Max Junction Temperature		150	°C
V _{ESD}	ESD Classification	Human Body Model ⁽²⁾	±4000	V
		Charged Device Model ⁽³⁾	±1000	
I _{LU}	Max Latch Up Current Above V _{CC} and GND at 125°C ⁽⁴⁾		±100	mA

Stresses exceeding those listed in the Maximum Ratings table may damage the device. If any of these limits are exceeded, device functionality should not be assumed, damage may occur and reliability may be affected.

Note1: I_O absolute maximum rating must be observed.

Note2: HBM tested per JEDEC JS-001;

Note3: CDM tested per JEDEC JS-002;

Note4: Latch Up Current Maximum Rating tested per JEDEC JESD78F.

Thermal Characteristics

Symbol	Package	Ratings	Value	Unit
R _{θJA}	SC70-5	Thermal Characteristics, Thermal Resistance, Junction-to-Air	300	°C/W
	SOT23-5		250	
	DFN6		440	
P _D	SC70-5	Power Dissipation in Still Air at 85°C	215	mW
	SOT23-5		260	
	DFN6		150	

ET74AHCT1G00

Recommended Operating Conditions

Symbol	Parameter	Min	Max	Unit
V _{CC}	DC Supply Voltage Operating	4.5	5.5	V
V _I	DC Input Voltage	0	V _{CC}	V
V _O	DC Output Voltage (High or Low State)	0	V _{CC}	V
T _A	Operating Temperature Range	-40	125	°C

Electrical Characteristics

DC Electrical Characteristics

Symbol	Parameter	Condition	V _{CC} (V)	T _A = 25°C			-40°C ≤ T _A ≤ 125°C		Unit
				Min	Typ	Max	Min	Max	
V _{IH}	High-Level Input Voltage		4.5	2			2		V
			5.5	2			2		
V _{IL}	Low-Level Input Voltage		4.5			0.8		0.8	V
			5.5			0.8		0.8	
V _{OH}	High-Level Output Voltage	I _{OH} = -50uA	4.5	4.4	4.5		4.4		V
		I _{OH} = -8mA		3.94			3.8		
V _{OL}	Low-Level Output Voltage	I _{OL} = 50uA	4.5			0.1		0.1	V
		I _{OL} = 8mA				0.36		0.44	
I _I	Input Leakage Current	V _I = 5.5V or GND	0~5.5			±0.1		±1.0	uA
I _{OFF}	Power Off Leakage Current	V _I = 5.5V or V _O = 5.5V	0			1		10	uA
I _{CC}	Quiescent Supply Current	V _I = 5.5V or GND	5.5			1		10	uA

ET74AHCT1G00

AC Electrical Characteristics

$t_r = t_f = 3\text{ns}$, over recommended operating free-air temperature range, $V_{CC} = 5\text{V} \pm 0.5\text{V}$ (unless otherwise noted)

Symbol	Parameter	Condition	$T_A = 25^\circ\text{C}$			$-40^\circ\text{C} \leq T_A \leq 125^\circ\text{C}$		Unit
			Min	Typ	Max	Min	Max	
t_{PLH}	Propagation Delay	$C_L = 15\text{pF}$		7	10	1.0	12	ns
t_{PHL}		$C_L = 50\text{pF}$		8.5	12	1.0	14	ns

Capacitance Characteristics

Symbol	Parameter	Condition	Typ	Unit
C_{IN}	Input Capacitance	$V_{CC} = 5\text{V}, V_I = 0\text{V or } V_{CC}$	5	pF
C_{PD}	Power Dissipation Capacitance ⁽⁵⁾	10MHz, $V_{CC} = 5\text{V}, V_I = 0\text{V or } V_{CC}$	21	pF

Note5: C_{PD} is used to determine the dynamic power dissipation (P_D in μW).

$$P_D = C_{PD} \times V_{CC}^2 \times f_i \times N + \Sigma(C_L \times V_{CC}^2 \times f_o) \text{ where:}$$

f_i = input frequency in MHz;

f_o = output frequency in MHz;

C_L = output load capacitance in pF;

V_{CC} = supply voltage in V;

N = number of inputs switching;

$\Sigma(C_L \times V_{CC}^2 \times f_o)$ = sum of outputs.

AC Test Circuit

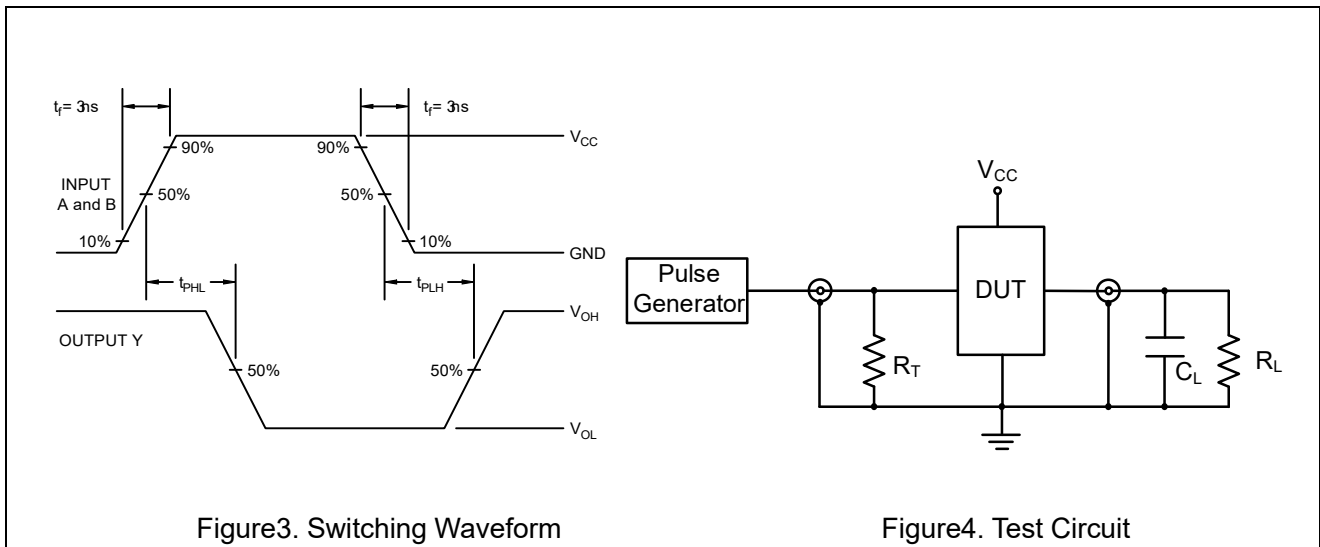

ET74AHCT1G00

Package Dimension

SC70-5 (1.3mm × 2.1mm)

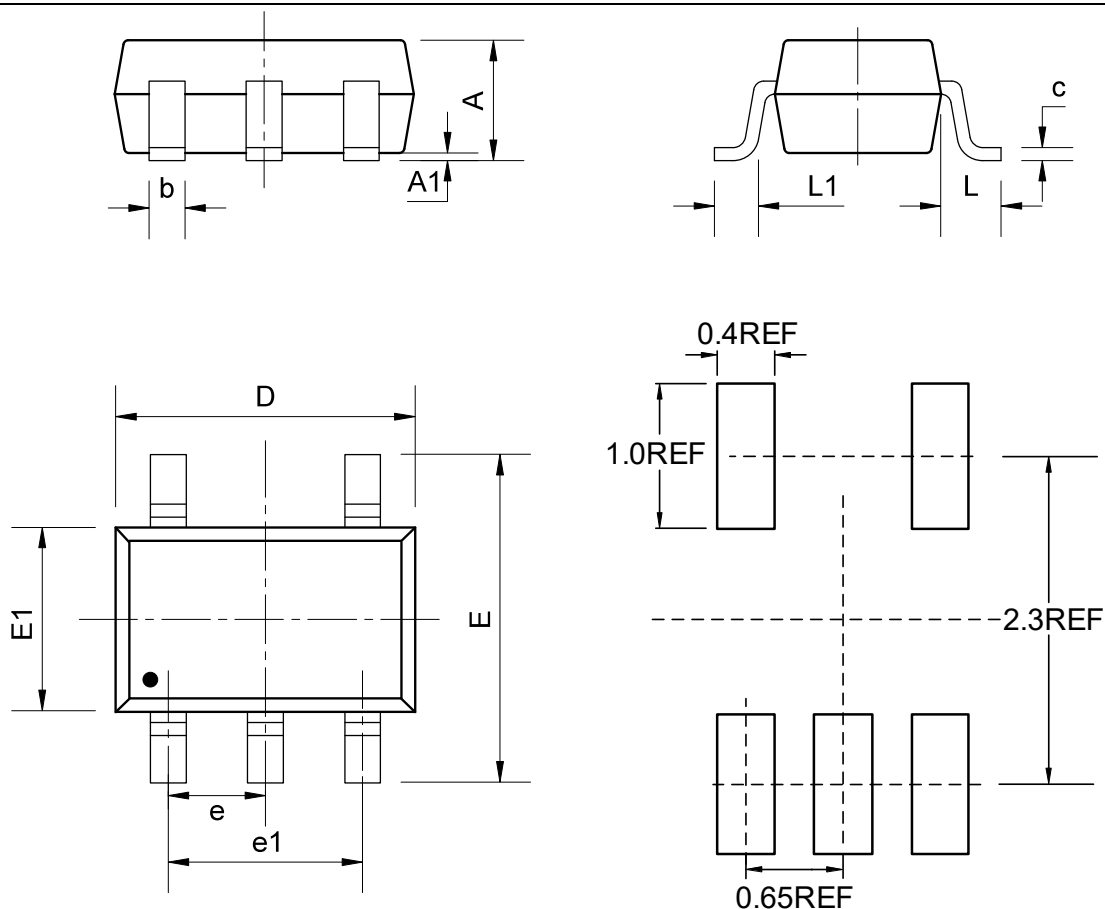

COMMON DIMENSIONS

(Unit: mm)

SYMBOL	MIN	NOM	MAX
A	-	-	1.10
A1	0.00	-	0.15
b	0.15	-	0.35
c	0.08	-	0.20
D	2.00	2.10	2.30
e	0.65BSC		
e1	1.30BSC		
E	2.15	2.30	2.50
E1	1.15	1.30	1.45
L	0.50REF		
L1	0.33REF		

ET74AHCT1G00

SOT23-5 (1.6mm × 2.9mm)

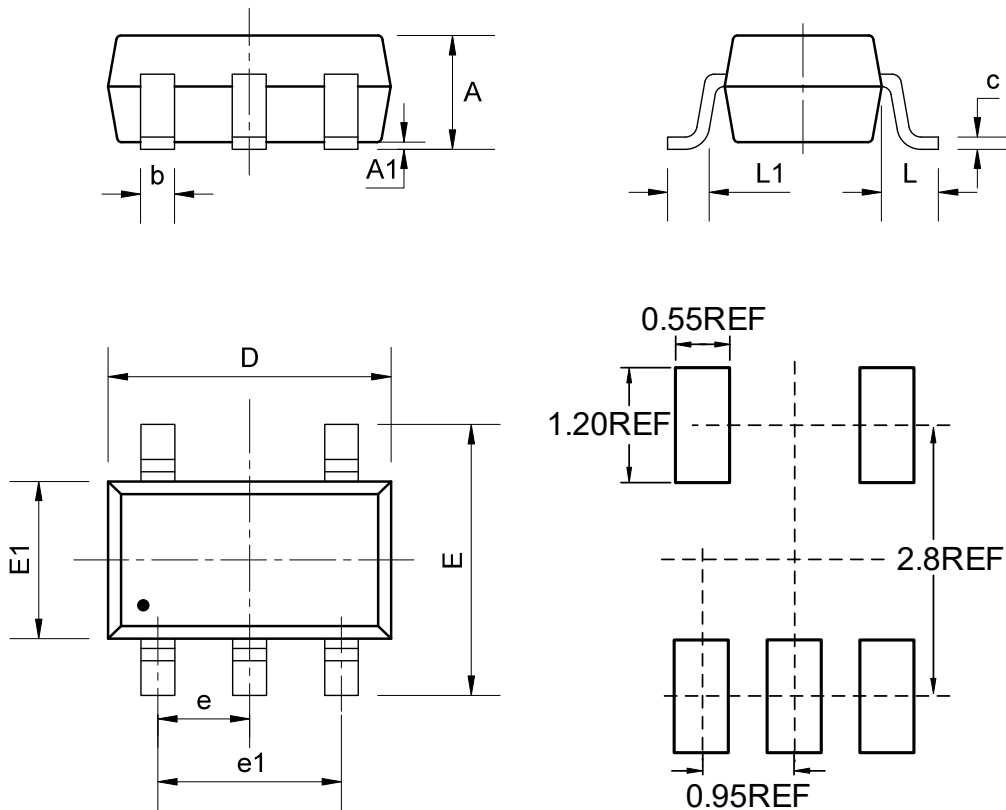

COMMON DIMENSIONS

(Unit: mm)

SYMBOL	MIN	NOM	MAX
A	-	-	1.45
A1	0.00	-	0.15
b	0.28	0.35	0.50
c	0.08	0.15	0.22
D	2.75	2.9	3.05
e	0.90	0.95	1.00
e1	1.80	1.90	2.00
E	2.60	2.80	3.00
E1	1.45	1.6	1.75
L	0.60REF		
L1	0.30	0.45	0.60

ET74AHCT1G00

DFN6 (1.0mm × 1.5mm)

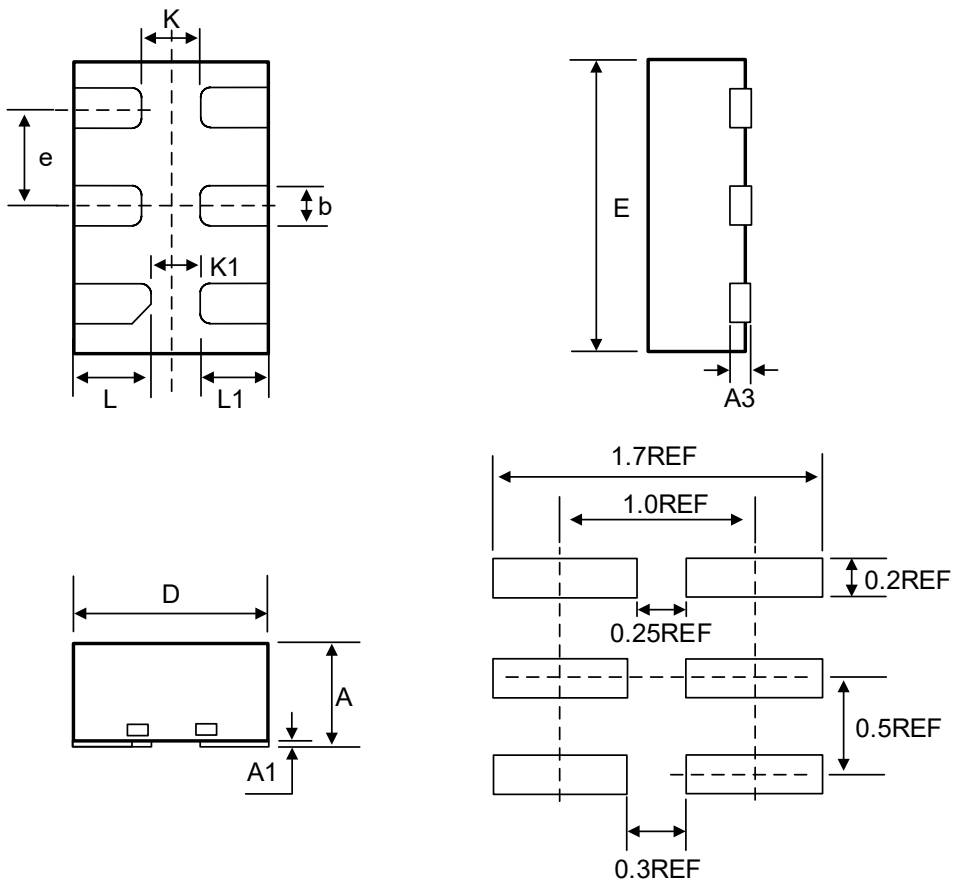

COMMON DIMENSIONS

(Unit: mm)

SYMBOL	MIN	NOM	MAX
A	0.50	--	0.60
A1	0.00	0.02	0.05
A3	0.10REF		
b	0.15	0.20	0.25
D	0.90	1.00	1.10
E	1.40	1.50	1.60
e	0.50BSC		
K	0.30REF		
K1	0.25REF		
L	0.35	0.40	0.45
L1	0.30	0.35	0.40

ET74AHCT1G00

Marking Information

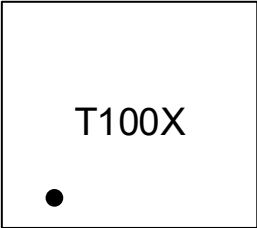
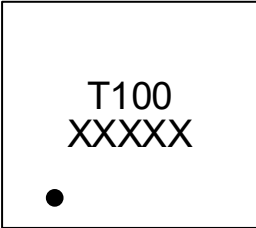
	
ET74AHCT1G00 T100 = Part Number X = Tracking Number	ET74AHCT1G00T T100 = Part Number XXXXX = Tracking Number

Revision History and Checking Table

Version	Date	Revision Item	Modifier	Function & Spec Checking	Package & Tape Checking
1.0	2025-10-28	Official Version	Wang anran	Yang xiaoxu	Liu jiaoying