

## 3.0 ~ 26V, 0.7 ~ 5A, Current Limit Power Switch with Output Over-Voltage Clamp and Reverse Block

### General Description

The ET20176HY is a current limit N-Channel MOSFET power switch. It is designed to protect circuitry on the output from transients on the input. It also protects the input from undesired shorts and transients coming from the output.

The current limit magnitude is controlled by an external resistor from ILIMIT to GND. It is fixed 2.5A when ILIMIT is floating. Programmable soft-start time controls the slew rate of the output voltage during the start-up time. It can be controlled by the DV/DT pin setting and MODE pin setting. The output voltage is limited by the OVP function. The clamping voltage can be set by the MODE connection.

The ET20176HY offer a GATE drive signal connected to an external N-Channel MOSFET gate to block current flowing from the output to the input when the IC is disable, power off or thermal shutdown.

### Features

- $V_{IN}$  Operating Range: 3.0V to 26V
- Programmable Current Limit and Soft-Start Time
- Selectable Over-Voltage Clamping Voltage
- Fast Output Over-Voltage Protection(OVP) Response
- Short-Circuit Protection
- Typical  $R_{ON}$ : 30m $\Omega$  From Input to Output Power Path
- Very Low Quiescent Current: 100 $\mu$ A (Typ)
- Reverse-Blocking MOSFET Driver
- Over-Current Protection (Hiccup Mode)
- Internal Thermal Shutdown Protection
- ESD Human Body Model (JESD22-A114) Protected: All pins  $\pm$ 2KV
- UL Listed- File No.E479717, Volume X2
- Package Information

Part No.	Package	MSL
ET20176HY	QFN10 (1.5mm $\times$ 2.0mm)	Level 1

### Application

- SSD Hard Disk
- PC Cards
- Wireless Modem Data Cards
- USB Power Distribution/USB Protection
- USB 3.1 Power Delivery
- Server PC

# ET20176HY

## Pin Configuration

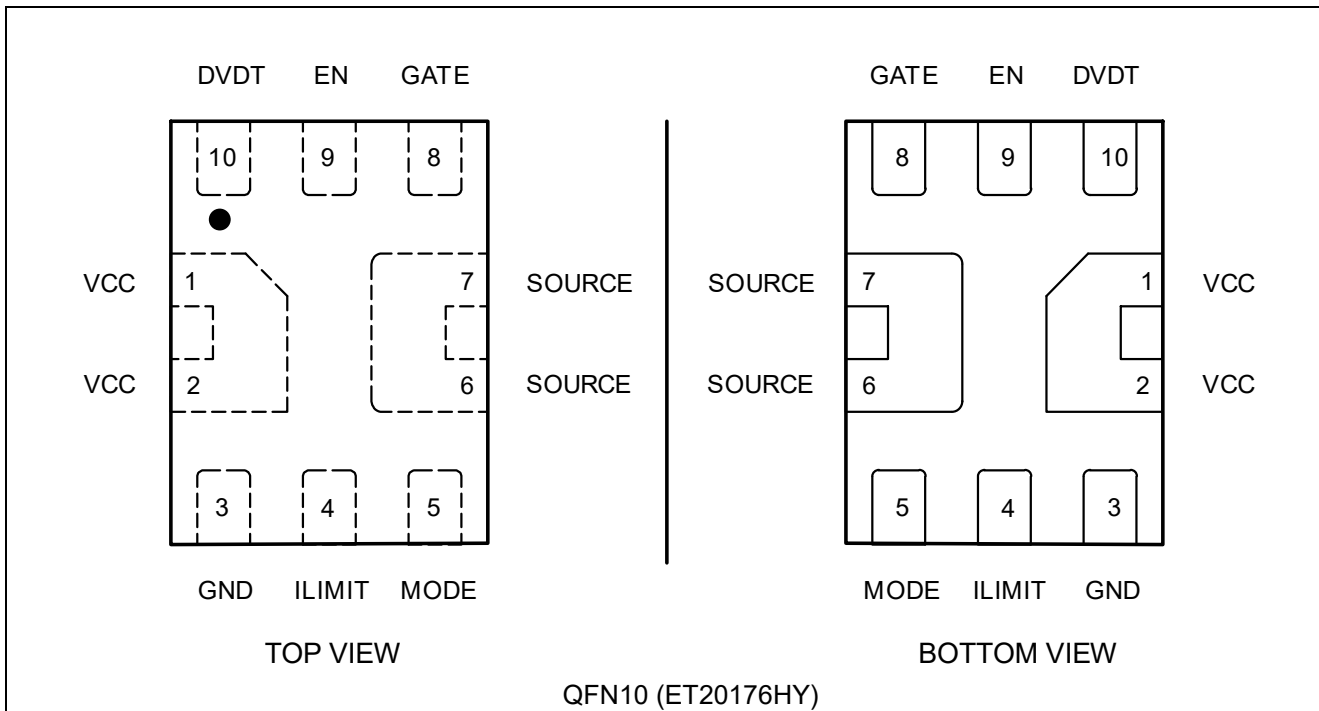

## Pin Function

Pin	Name	Description
1,2	VCC	Power supply input. Must be closely decoupled to GND pins with a 1uF or greater ceramic capacitor. Connect VCC using a wide PCB trace.
3	GND	Ground pin.
4	ILIMIT	Current limit programming pin. Program the current limit by connecting a resistor to GND. Floating ILIMIT pin to achieve a 2.5A fixed current limit.
5	MODE	Output over-voltage protection clamp voltage select pin. Connecting a resistor to GND to sets the OVP threshold voltage. Three digital inputs are provided for MODE as VCC/GND/Floating.
6,7	SOURCE	Source of internal power n-channel MOSFET and the output terminal.
8	GATE	Gate pin for external reverse-current block MOSFET.
9	EN	Enable pin. Force EN high to enable the IC. Floating or pull to GND to disable the IC. Full EN up to VCC through a 300kΩ resistor for quick start-up mode.
10	DV/DT	Soft start programming pin. Connect a capacity from DV/DT to GND to set the DV/DT slew rate.

# ET20176HY

## Block Diagram

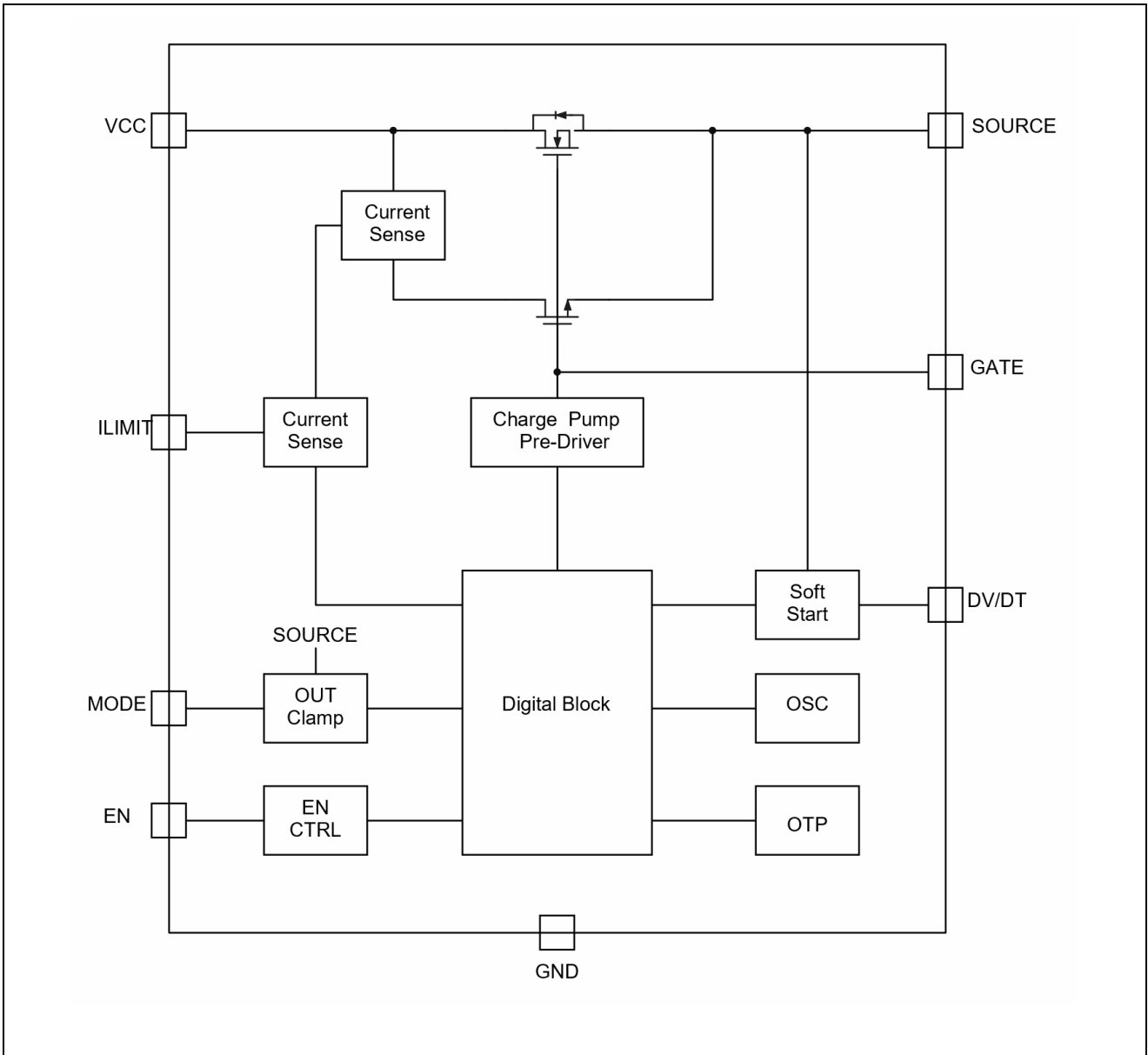

# ET20176HY

---

## Operation

ET20176HY is an an integrated power switch with a low Rdson N-Channel MOSFET, programmable current limiting and OVP clamp voltage. When the ET20176HY turns on, it can deliver up to 5A continuous current to load. When the device is active, the device only consumes 90uA supply current if no load.

## Power Supply Considerations

A 10µF MLCC capacitor between IN and GND, close to the device, is recommended. Placing a high-value electrolytic capacitor on the output pin(s) is recommended when the output load is heavy. This precaution reduces power-supply transients that may cause ringing on the input and minimize the input voltage droops. Additionally, bypassing the output with a 10µF MLCC capacitor improves the immunity of the device to short-circuit transients.

## Current Limit (ILIMIT)

A sense FET is employed to check for over current conditions. When an over current condition is detected, the device maintains a constant output current and reduces the output voltage accordingly. ET20176HY will limit the current until the overload condition is removed or the device begins to thermal cycle.

The current limit can be programmed by an external resistor. It can be approximated with equation below.

$$I_{LIMIT} = \frac{0.55}{R_{LIMIT}} \times 3870$$

If the current limit condition lasts longer than 2ms, the ET20176HY enters hiccup mode with 2ms of on time and 700ms of off time.

The ET20176HY allows ILIMIT to be floated during operation. The internal fixed current limit threshold is set at 2.5A. The current limit response time is about 40us<sup>(1)</sup>.

When short ILIMIT to GND, the normal current limit function is disabled, but the secondary current limit still works. The secondary current limit is set at 8A. When the OCP is triggered, the power MOSFET will be shutdown immediately.

## Short-Circuit Protection(SCP)

The secondary current limit is set at 8A. If the load current reaches 8A rapidly due to a short-circuit event, a fast turn-off circuit activates to turn off the MOSFET. The total short-circuit response time is about 3us(1). After switched off, the MOSFET restarts. If the short still exists, the ET20176HY regulates the MOSFET to hold the current at threshold level. If it lasts for 2ms, the MOSFET will be turned off again and restart when re-enable or re-power-on.

To prevent safe operating area(SOA) damage during a high input voltage short-circuit protection(SCP) condition, the IC current limit folds back when the power MOSFET VDS voltage is above the typical 11V and the junction temperature is over 100°C.

# ET20176HY

---

## OVP Clamp Voltage

The OVP clamp voltage can be programmed by MODE pin. Three digital inputs are provided for MODE. Drive MODE to VCC to set the OVP clamp voltage at 15.2V. Drive MODE to GND to set it at 5.75V. Float MODE pin for no clamp function. Also clamp voltage can be set by connecting a resistor from MODE to GND.

## Soft Start

The soft start time can be set by an external capacity connecting from DV/DT to GND. Different clamp MODE have different soft start time. The soft start time can be calculated with Equation:

$$t_{ss}(ms) = \frac{V_{IN}(V)}{dV/dt(V/ms)}$$

The dV/dt slew rate is determined by external DVDT capacitor and voltage clamp mode.

## Reverse-Blocking MOSFET Driver

The ET20176HY has a GATE pin to provide an external N-channel MOSFET gate drive signal for reverse-current blocking (RCB). Three events can pull down the GATE voltage: VIN below the under-voltage lockout (UVLO), the enable (EN) voltage below the low level threshold, or thermal shutdown. If any of these conditions occur, GATE sinks the current from the gate of the external MOSFET to initiate a fast turn-off.

For 3.3V low input voltage application, it is recommended to choose a small threshold voltage(VGS<1.6V) reverse-blocking MOSFET to reduce the voltage drop.

A 100pF capacitor is required on GATE if it is not connected to external MOSFET.

## Thermal Protection

Thermal protection prevents damage to the IC when heavy-overload or short-circuit faults are present for extended periods of time. The ET20176HY implements a thermal sensing to monitor the operating junction temperature of the power MOSFET. In an over-current or short-circuit condition, the junction temperature rises due to excessive power dissipation.

Once the die temperature rises to approximately 155°C due to over-current conditions, the internal thermal sense circuitry turns the power switch off, thus preventing the power switch from damage. When the temperature drops below its lower threshold (typically 125°C), the chip is enable again after a 700ms delay.

**Note1:** Test condition is as  $V_{IN}=5V$ ,  $I_{LIM}=2.5A$ ,  $T_A=25^{\circ}C$ ,  $C_{OUT}=0\mu F$ . Current Limit Response Time is the time difference between  $I_{OUT}$  first exceeding  $I_{LIM}$  and falling back to  $I_{LIM}$ . and falling back to  $I_{LIM}$ . Short-circuit Response Time is the time difference between  $I_{OUT}$  exceeding 8A and falling back to 0A.

# ET20176HY

## Absolute Maximum Ratings

Symbol	Parameters	Min	Max	Unit	
V <sub>CC</sub> , V <sub>SOURCE</sub>	V <sub>CC</sub> , SOURCE to GND	-0.3	29	V	
V <sub>MODE</sub>	MODE to GND	-0.3	29	V	
V <sub>GATE</sub>	GATE to GND	-0.3	V <sub>SOURCE</sub> +5.5	V	
V <sub>ILIMIT</sub> , V <sub>EN</sub> , V <sub>DVDT</sub>	ILIMIT, EN, DV/DT to GND	-0.3	7	V	
P <sub>D</sub>	Power Dissipation at T <sub>A</sub> = +85°C <sup>(1)(3)</sup>		1.05	W	
T <sub>J</sub>	Junction Temperature	-40	+150	°C	
T <sub>STG</sub>	Storage Junction Temperature	-65	+150	°C	
T <sub>SOLD</sub>	Soldering Temperature (reflow)		+260	°C	
V <sub>ESD</sub>	Electrostatic Discharge Capability	Human Body Mode, ESDA/JEDEC JS-001-2017	-2	+2	KV
		Charged Device Mode, ESDA/JEDEC JS-002-2018	-1.5	+1.5	KV

## Thermal Resistance

Package	PCB Version	θ <sub>JA</sub>	θ <sub>JC</sub>	Unit
QFN10(1.5mm*2.0mm)	ETPB4433 <sup>(2)</sup>	89	26	°C/W
	ETPB3624 <sup>(3)</sup>	75	18	°C/W
	ETPB4433 <sup>(4)</sup>	63	15	°C/W

### Notes:

1. The maximum allowable Power Dissipation is recording to maximum allowable Junction Temperature.

$$P_{D(MAX)} @ T_A = (T_{J(MAX)} - T_A) / \theta_{JA}$$

2. Measured on ETPB4433, 1-layer PCB, 1oz Cu, 60mmx42mm.

3. Measured on ETPB4433, 2-layer PCB, 1oz Cu, 60mmx42mm.

4. Measured on ETPB4433, 2-layer PCB, 2oz Cu, 60mmx42mm.

## Recommended Operating Conditions

Symbol	Parameter	Min	Max	Unit
V <sub>IN</sub>	DC Input Voltage	3.0	26	V
I <sub>OUT</sub>	DC Output Current Limit	0.7	5.0	A
T <sub>A</sub>	Operating Temperature Range	-40	+85	°C

# ET20176HY

## Electrical Characteristics

Unless otherwise noted,  $V_{CC}=5V$ ,  $R_{LIMIT}=NS$ ,  $C_{OUT}=10\mu F$ ,  $T_A=-40^{\circ}C+85^{\circ}C$ , typical value is tested at  $T_A=25^{\circ}C$ .

Symbol	Parameters	Conditions	Min	Typ	Max	Unit
<b>Basic Operation</b>						
$V_{IN}$	Input Voltage		3.0		26	V
$I_Q$	$V_{IN}$ Quiescent Current	EN = High MODE = VCC/GND/float		60	100	$\mu A$
		EN = High MODE series resistor to GND		100	150	$\mu A$
$I_S$	$V_{IN}$ Shutdown Current	EN = GND		5	15	$\mu A$
<b>Power MOSFET</b>						
$R_{ON}$	On-Resistance of Switch IN-OUT	$I_{OUT}=1A$		30	60	m $\Omega$
$t_{DELAY}$	Turn-on Delay Time	DV/DT float, MODE float		500		$\mu s$
$I_{OFF}$	Off-state Leakage Current	$V_{CC} = 12V, V_{EN} = GND$		0.1	1	$\mu A$
$V_{UVLO\_R}$	Under Voltage Lockout Threshold	$V_{IN}$ Rising	2.6	2.8	3.0	V
$V_{UNLOHYS}$	UVLO Hysteresis			200		mV
$V_{CLAMP}$	Output clamping voltage <sup>(1)</sup>	$V_{MODE} = GND$	5.5	5.75	6	V
		$V_{MODE} = VCC$	14.2	15.2	16.2	V
		$R_{MODE} = 76.8k\Omega$	3.60	3.84	4.08	V
		$R_{MODE} = 115k\Omega$	5.35	5.75	6.15	V
		$R_{MODE} = 324k\Omega$	14.9	16.2	17.5	V
		$R_{MODE} = 422k\Omega$	19.3	21.1	22.9	V
<b>DV/DT</b>						
$D_V/D_T$	DV/DT slew rate	DV/DT float, $V_{MODE} = GND$	0.4	0.8	1.2	V/ms
		DV/DT float, $V_{MODE} = VCC$	1.3	2	2.7	V/ms
		DV/DT float, MODE float	2.8	3.8	4.8	V/ms
$I_{DV/DT}$	DV/DT current <sup>(2)</sup>	$V_{DV/DT} = 0.5V$		6.5		$\mu A$
<b>Current Limit</b>						
$I_{LIMIT\_NO}$	Current limit at normal operation <sup>(3)</sup>	$I_{LIMIT}$ float, $V_{CC}=5V$	2.3	2.5	2.7	A
		$R_{LIMIT} = 604\Omega, V_{CC}=5V$	3.3	3.5	3.7	A
		$R_{LIMIT} = 3k\Omega, V_{CC}=5V$	0.6	0.75	0.9	A
<b>Enable (EN)</b>						
$V_{EN\_RISING}$	EN rising threshold		1.86	2	2.16	V
$V_{EN\_HYS}$	EN hysteresis			350		mV
$R_{EN}$	EN pull-down resistor		1.4	2.2	3.0	M $\Omega$

# ET20176HY

## Electrical Characteristics (Continued)

Unless otherwise noted,  $V_{CC}=5V$ ,  $R_{LIMIT}=NS$ ,  $C_{OUT}=10\mu F$ ,  $T_A=-40^{\circ}C+85^{\circ}C$ , typical value is tested at  $T_A=25^{\circ}C$ .

Symbol	Parameters	Conditions	Min	Typ	Max	Unit
<b>GATE</b>						
$I_{G\_SOURCE}$	GATE Maximum Source Current	$I_{OUT} = 1A$	7	12		$\mu A$
$I_{G\_SINK}$	GATE Maximum Sink Current	$V_{CC} = V_{SOURCE} = 5.5V$ , $V_{GATE} = 10.5V$		3		mA
<b>Output Discharge</b>						
$R_{DIS}$	Discharge resistor		580	980	1300	$\Omega$
<b>Over-Temperature Protection</b>						
$T_{SD}$	Thermal Shutdown			155		$^{\circ}C$
$T_{SD\_HYS}$	Thermal-shutdown Hysteresis			30		$^{\circ}C$

### Notes:

- The OVP clamp threshold can be set by connecting a resistor from MODE to GND as below.

$$V_{CLAMP} = 0.05 \times R_{MODE} \text{ (k}\Omega\text{)}$$

- For cases with an external DV/DT capacitor, the slew rate of  $V_{SOURCE}$  can be calculated with equation:

$$dv/dt(V/ms) = \frac{6.5\mu \times K1}{C_{DV/DT}(nF)}$$

K1 factor is as below.

MODE Connection	K1
GND	5.75
VCC	15.2
FLOAT	27
$R_{MODE}$	$\frac{V_{CLAMP}}{6.8\mu \times R_{MODE}}$

- The current limit can be approximated with Equation below.

$$I_{LIMIT} = \frac{0.55}{R_{LIMIT}} \times 3870$$

# ET20176HY

## Typical Performance Characteristics

Unless otherwise noted,  $V_{CC}=5V$ ,  $V_{EN}=5V$ ,  $R_{LIMIT}=604\Omega$ ,  $C_{OUT}=10\mu F$ , MODE floating, DVDT floating,  $T_A=25^\circ C$ .

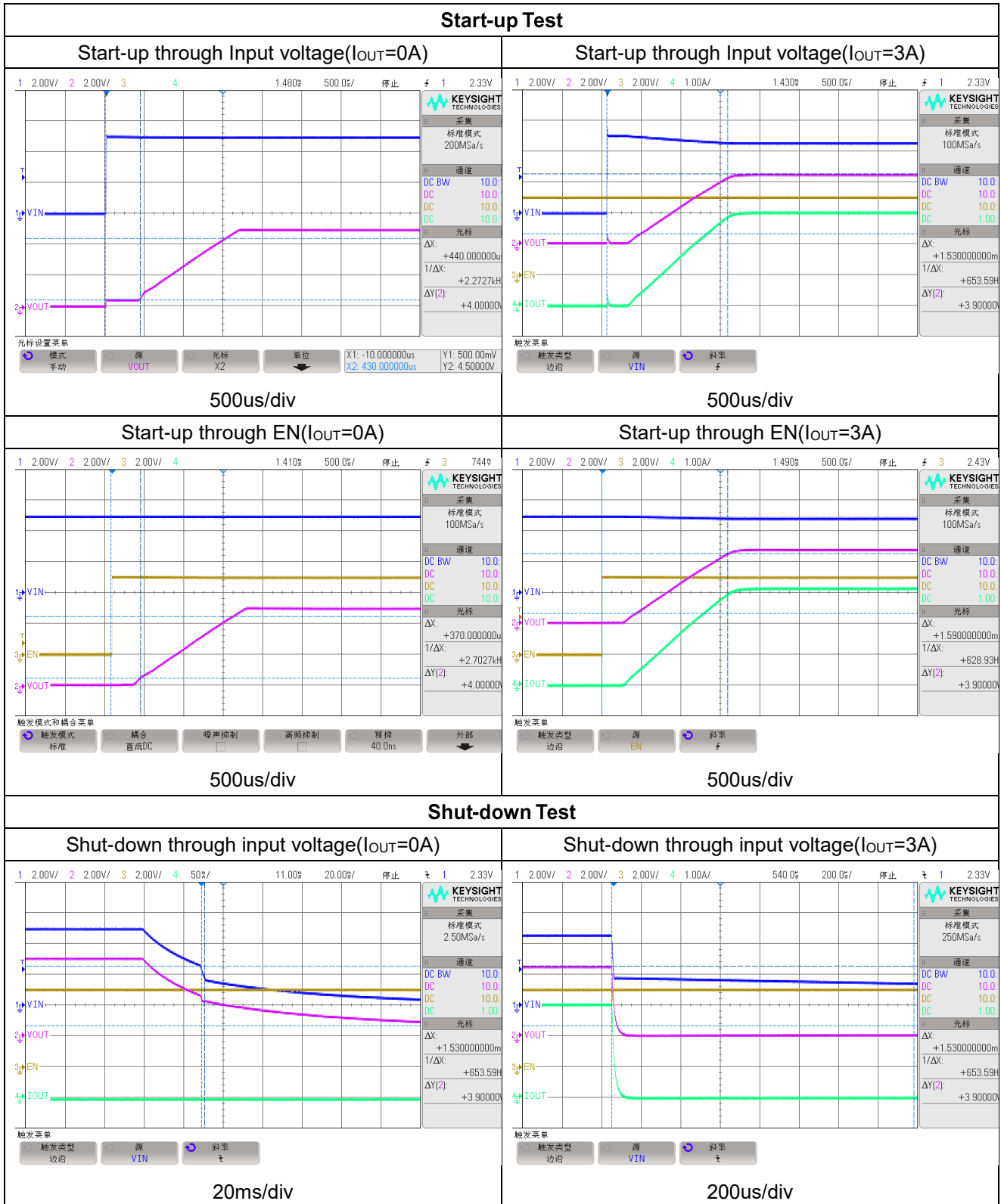

# ET20176HY

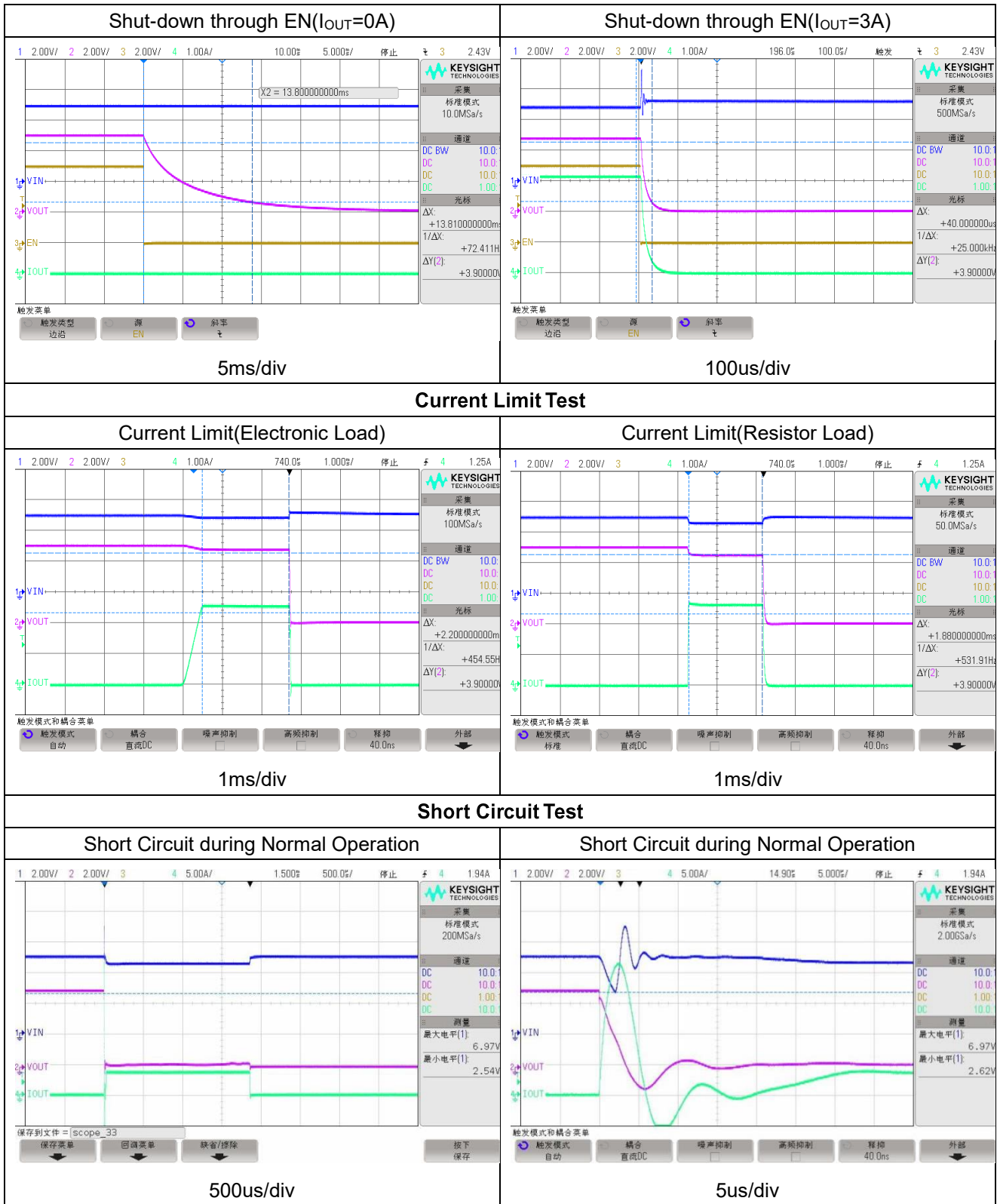

# ET20176HY

## Application Circuits

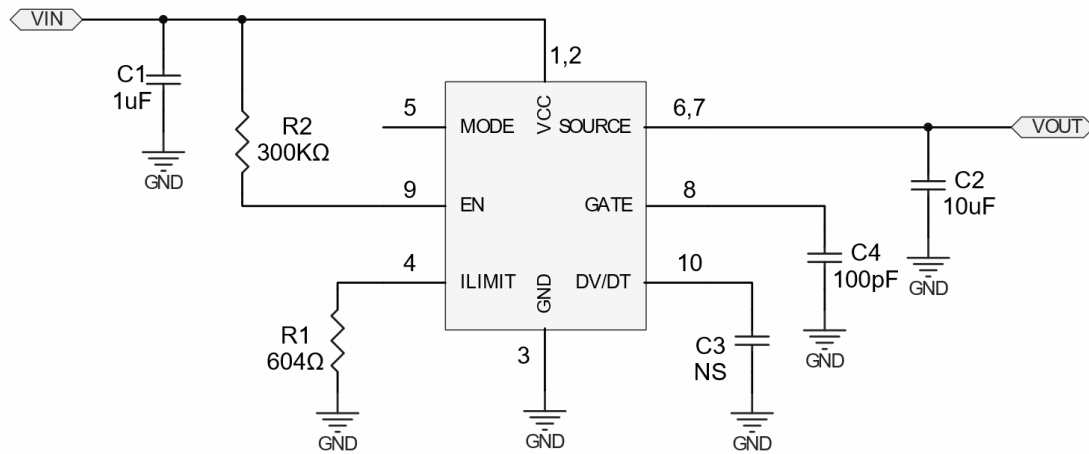

Typical Application Circuit without RCB Mosfet

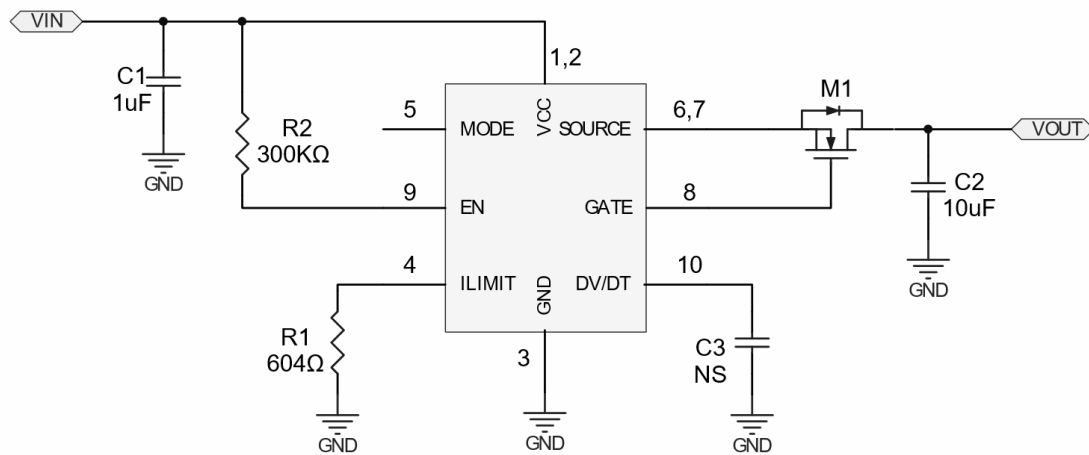

Typical Application Circuit with RCB Mosfet

\*: This electric circuit only supplies for reference.

# ET20176HY

## PCB Layout Guide

PCB layout is very important to achieve stable operation. It is highly recommended to duplicate EVB layout for optimum performance. If change is necessary, please follow these guidelines for reference.

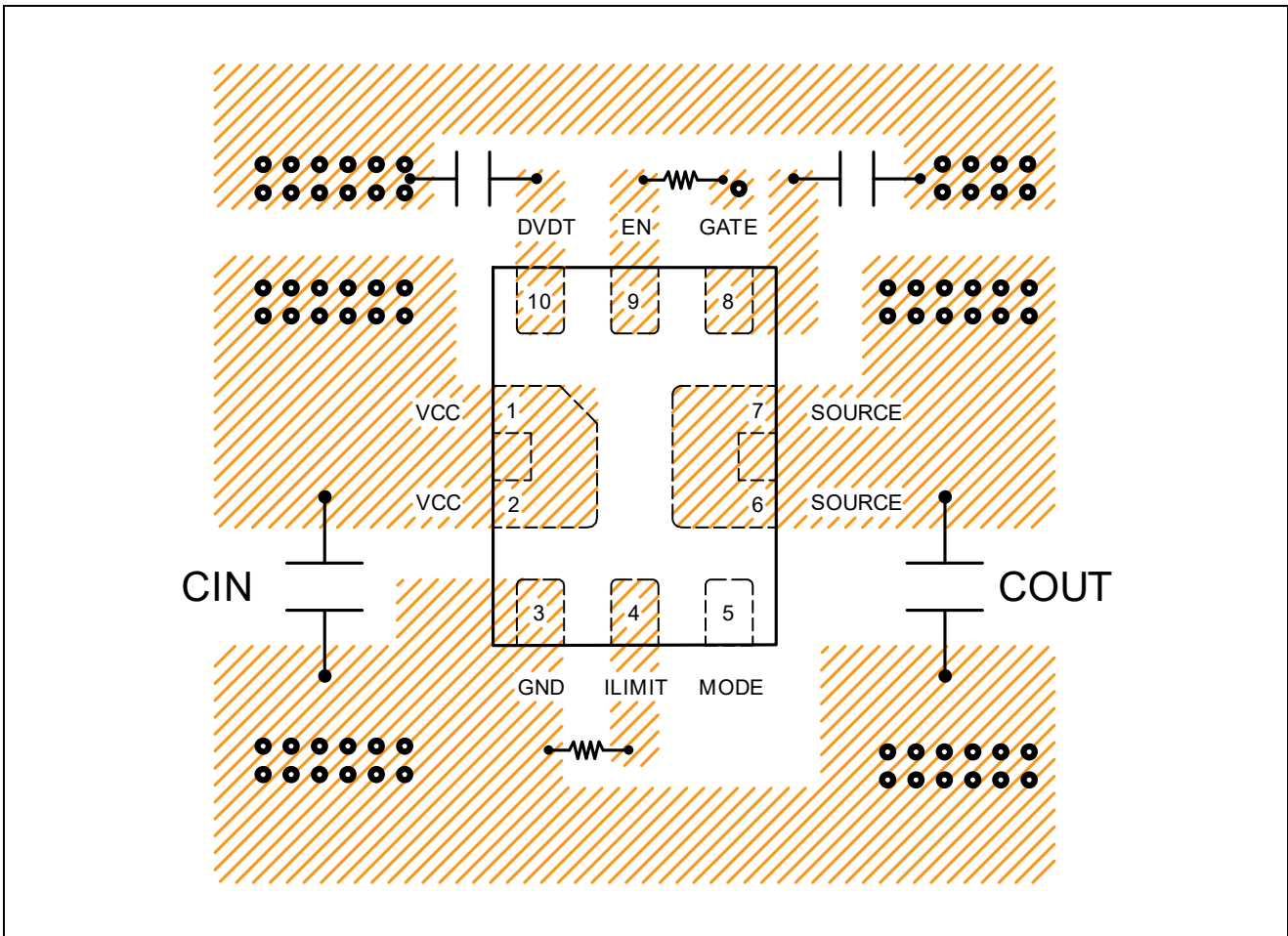

- 1) Keep the path of current short and minimize the loop area formed by Input and output capacitor.
- 2) Output capacitor and IC must be on the same side. The distance of output pin and output capacitor <math>< 3\text{mm}</math> is recommended.
- 3) Bypass ceramic capacitors are suggested to be put close to the VIN Pin.
- 4) Connect IN, OUT, and especially GND respectively to a large copper area to cool the chip to improve thermal performance and long-term reliability.
- 5) Place a current-limit resistor close to ILIMIT.
- 6) Place the DV/DT capacitor close to DV/DT.

# ET20176HY

## Package Dimension

QFN10

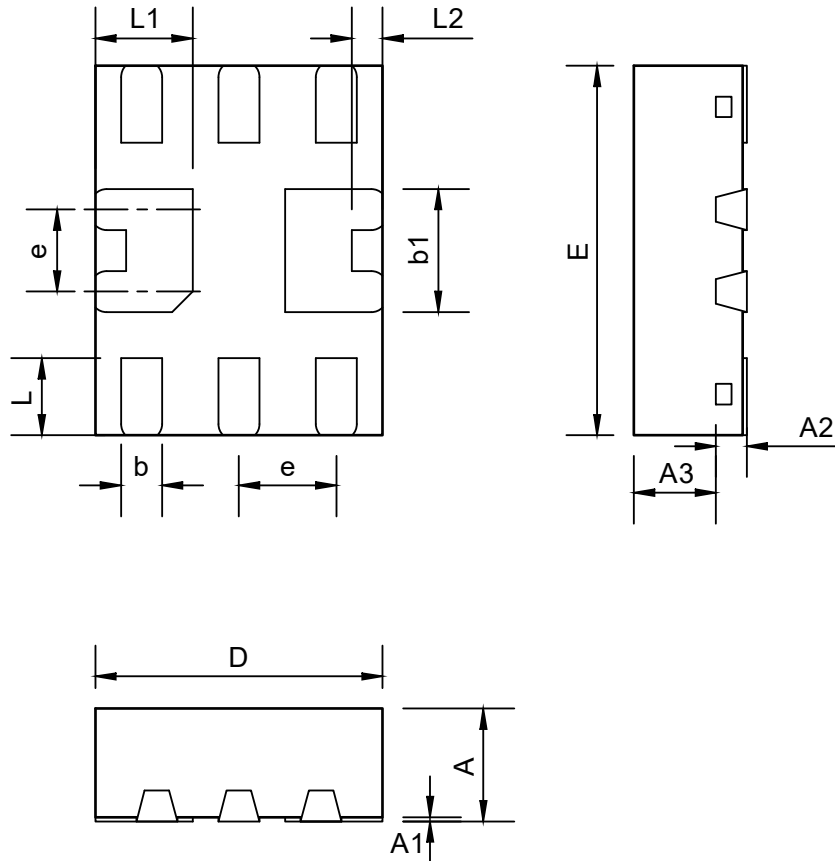

COMMON DIMENSIONS  
(UNITS OF MEASURE=MILLIMETER)

SYMBOL	MIN	NOM	MAX
A	0.80	0.85	0.90
A1	0.00	0.02	0.05
A2	0.203REF		
A3	0.60	0.65	0.70
b	0.20	0.25	0.30
b1	0.70	0.75	0.80
D	1.45	1.50	1.55
E	1.95	2.00	2.05
e	0.50BSC		
L	0.30	0.35	0.40
L1	0.50	0.55	0.60
L2	0.15	0.20	0.25



# ET20176HY

---

## Marking

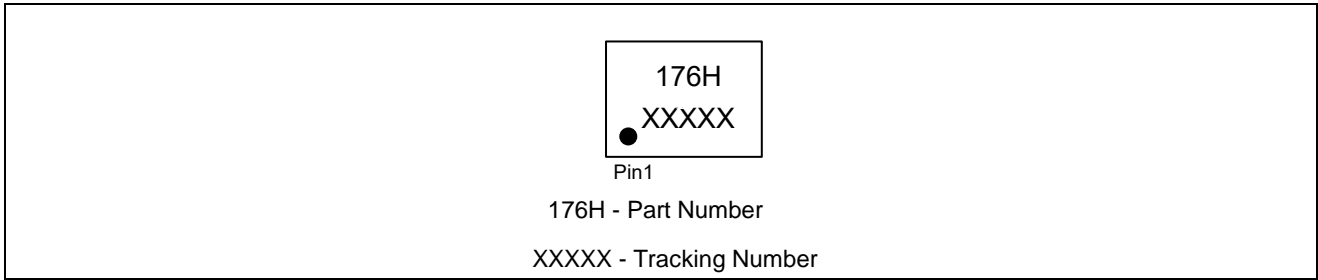

## Revision History and Checking Table

Version	Date	Revision Item	Modifier	Function & Spec Checking	Package & Tape Checking
1.0	2022-04-12	Initial Version	Yangz	Yangz	Zhuji
1.1	2023-12-6	Add Marking	Shibo	yangz	Liuji
1.2	2025-6-20	Update Format	Caojc	Yangz	Liuji
1.3	2025-9-20	Add UL No. ,Simplified Reel diagram	Shibo	Yangz	Liuji